

Merlin[®]

with Security⁺ 2.0

APPLICATION

The receiver can be used as a single or three channel receiver to control up to 3 gates, commercial operators or residential door openers. The receiver can also be used with a 3-button remote control to operate the OPEN, CLOSE and STOP feature on a commercial door operator.

Each channel is compatible with a specified number of remote controls and keypads. Refer to the list below:

- CH1: 50 remote controls and 2 separate keypads
- CH2: 20 remote controls and 2 separate keypads
- CH3: 20 remote controls and 2 separate keypads

CH1 & CH2 have Normally Open dry contact outputs.

CH3 has both Normally Open & Normally Closed dry contact outputs.

When the channel has reached full capacity for remote controls, all LEDs will blink 3 times. When the channel has reached full capacity for keypads, all LEDs will blink 4 times. Additional accessories can be programmed, however, the newly programmed accessory will replace the first programmed accessory.

NOTE: The receiver will only allow you to program a button on the remote control to one channel at a time. For example, if the button on the remote control or keypad is already programmed to channel 1 and then is programmed to channel 3, the button will be erased from channel 1 and will only work on channel 3.

Momentary Closure:

The outputs are automatically programmed for a momentary closure of 0.4 seconds when using hand held remote controls E945M, etc.

Constant Closure Output:

The outputs are automatically programmed to remain closed when receiving a constant signal (press & hold) only when using Keypads and Wireless Wall Controls, E840M, E128M, E138M etc.

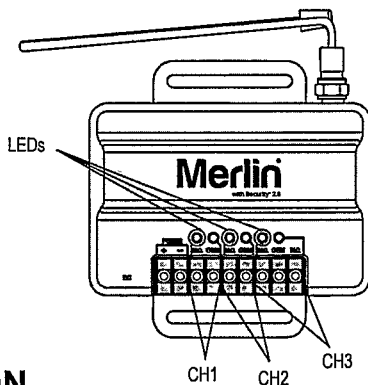

INSTALLATION

The receiver and antenna use TV Type F coaxial connectors. The antenna can be connected directly to the receiver or it can be installed remotely using a coaxial cable extension kit (Model 86LM, 5m).

- 1 Select a location for the receiver which allows access to the terminals and space for the antenna. Ensure antenna does not touch metal surfaces. DO NOT bend or fold the antenna.
- 2 Fasten the receiver securely with the hook and loop fasteners (provided) or screws (not provided).
- 3 After installation is complete, connect power. You may use a wired-in transformer, or power provided from your operator (9-30 V AC, 12-40 Vdc).

3-CHANNEL UNIVERSAL RECEIVER MODEL E8003

⚠️ WARNING

To prevent possible SERIOUS INJURY or DEATH from electrocution:

- Be sure power is NOT connected BEFORE installing the receiver.

To prevent possible SERIOUS INJURY or DEATH from a moving gate or garage door:

- ALWAYS keep remote controls out of reach of children. NEVER permit children to operate, or play with remote control transmitters.
- Activate gate or door ONLY when it can be seen clearly, is properly adjusted, and there are no obstructions to door travel.
- ALWAYS keep gate or garage door in sight until completely closed. NEVER permit anyone to cross path of moving gate or door.

⚠️ WARNING

To prevent possible SERIOUS INJURY or DEATH, the use of CONSTANT OPERATION on residential openers is PROHIBITED.

When a receiver is used to activate a commercial door opener, a reversing edge MUST be installed on the bottom of the door. Failure to install a reversing edge under these circumstances may result in SERIOUS INJURY or DEATH to persons trapped beneath the door.

WIRING

Refer to your commercial door operator or gate operator owner manual or wiring diagrams for specific wiring information.

SINGLE CHANNEL

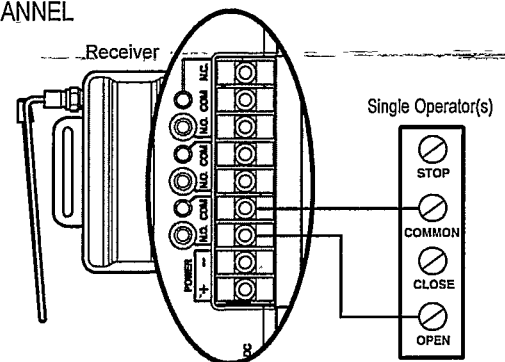

THREE CHANNEL

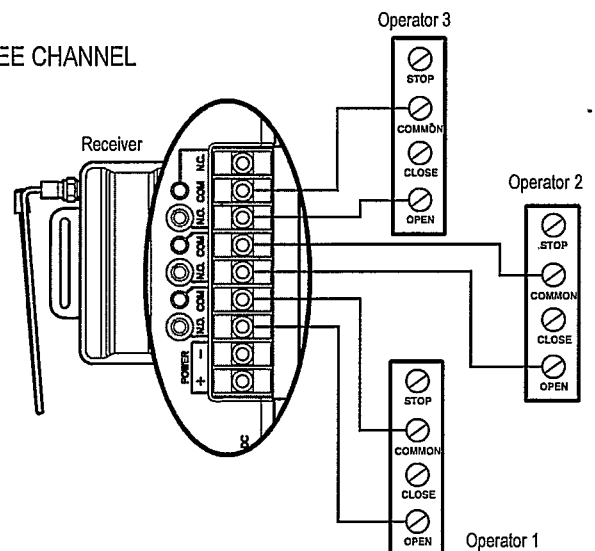

WIRING CONTINUED

OPEN, CLOSE, STOP

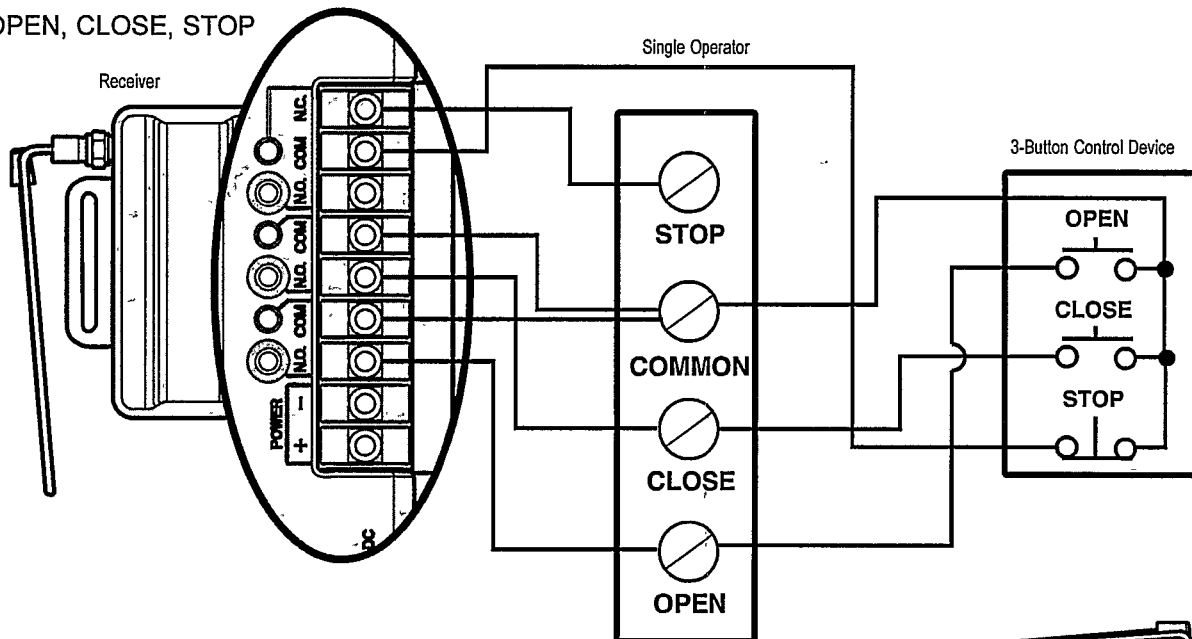

Refer to your door operator or gate operator wiring diagrams for instructions on connecting two or more 3-Button control devices.

PROGRAMMING

PROGRAM A SINGLE BUTTON REMOTE CONTROL

- 1 Press and release the Learn button for the selected channel on the receiver. The corresponding LED will glow steadily for 30 seconds.
 - 2 Within 30 seconds press and hold the button on the remote control that you wish to program to the receiver.
 - 3 Release the remote control button when the LED on the receiver blinks, then turns off. Programming is complete.
- Repeat the steps above for each remote control you would like to program.

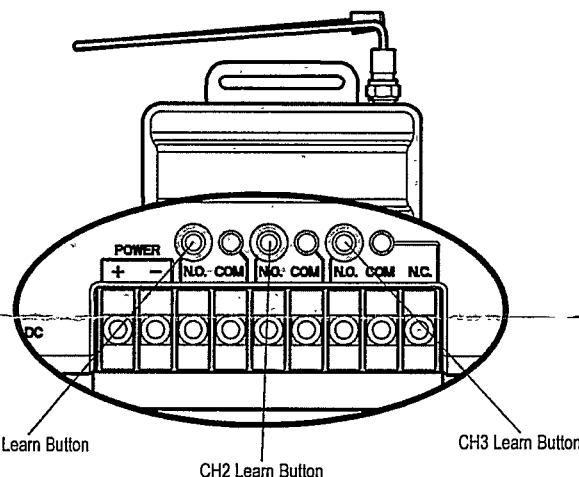

PROGRAM A 3-BUTTON REMOTE CONTROL AS OPEN, CLOSE, AND STOP

- 1 Press and release the CH1 Learn button on the receiver.
- 2 Within 30 seconds press the desired OPEN button on the remote control.
- 3 Press and release the CH2 Learn button on the receiver.
- 4 Within 30 seconds press the desired CLOSE button on the remote control.
- 5 Press and release the CH3 Learn button on the receiver.
- 6 Within 30 seconds press the desired STOP button on the remote control.

NOTE: If a remote control button is not pressed within 30 seconds, the LED next to the selected Learn button will turn OFF. In that case, repeat the programming.

TO ERASE THE MEMORY

- 1 Press and hold the Learn button for the channel you want to erase. Release the button when the corresponding LED turns off; the memory has been erased.

SPECIFICATIONS

Contact Rating 5 Amps 28 Vac or dc Max.
 Power 9-30V AC or 12-40 VDC, 50mA
 RF Frequency: 433MHz

NOTE: If your operator does not meet the power specifications you will need a low voltage power supply.
 For indoor installation only.

COMPATIBLE ACCESSORIES

Remote Controls Models E945M, E940M, E943M,
 Keypads Models E840M
 Wireless Wall Controls Models E128M, E138M
 Antenna Extension Kits Models 86LM,
 Antenna Only K77-36541

CHAMBERLAIN AUSTRALIA PTY LTD
 PO BOX 1446
 LANE COVE NSW 1595
 PHONE TOLL FREE: 1800 638 234

CHAMBERLAIN NEW ZEALAND LTD
 PO BOX 100-221
 NORTH SHORE 0745
 PHONE TOLL FREE: 0800 MERLIN

gomerlin.com.au
 gomerlin.co.nz



FOR TECHNICAL SUPPORT DIAL OUR TOLL FREE NUMBER:
 1800 638 234

114A4463B