

# PCR43302R, PCR43302RE

2-Channel, 433MHz Penta Receiver with Relay outputs

## Features

- Frequency hopping between 433.10 to 434.70MHz
- Coding using 12-way dipswitch or encrypted codes
- Momentary and latching modes are user selectable.
- Antenna diversity for robust link with extended range
- Unlimited remotes can be programmed to the receiver
- Compatible with PentaFOB® and PentaCODE® remotes
- Wide operating supply voltage and low current consumption
- Add, edit and delete individual PentaFOB remotes with programmer
- On-board diagnostic LED's to indicate correct power, reception and relay activation



## Applications

- Keyless access control for automatic gates and doors
- Home automation i.e. garden lights, swimming pool control etc.
- Security, lighting and automotive controls

.... and anywhere else you need a wireless signal to transmit a contact closure

## Description

**PCR43302R** - PCB only. Easily integrates into custom cases

**PCR43302RE** - Comes enclosed in an IP66 rated case

This receiver is compatible with “PentaFOB®” and “PentaCODE®” remotes. The receiver can be easily installed into your existing automatic gate opener or garage door controls. Other applications include light control, security shutters or anywhere else you need a wireless signal to transmit a contact closure.

The PentaCODE® dual coding system gives the installer the option to use the classic 12-way dip switch coding or one of over 17 billion encrypted codes.

With the 12-way dip switch, just match the keyring remotes and the receiver's dip switch and it's coded. With the encrypted code you switch all the 12-way dip switches OFF and the remote and receiver automatically goes into the encrypted coding. Please see coding instructions for encrypted coding procedure.

## Output Modes

Relay output on the receiver can function in either momentary or latching mode. By default the mode is set to momentary. To change it to latching links need to be cut. There are 2 links, one for each output.

### Factory Default = Momentary

**Momentary** - Output is active for as long as the transmitter button is pressed.

*This is a standard mode on most automatic gates or garage door openers.*

**Latching** - Output remains active until next press of the transmitter button.

*Similar to switching "on" and "off" a light.*

## Customised Software

Custom output modes can be programmed to do special functions. Call Elsema for more details.

**Products in the Range**

			
<p><b>PCR43301RE</b> 1-Channel Receiver with Relay Output. Enclosed in a case</p>	<p><b>PCR43302P</b> 2-Channel Plug in type Receiver with Open Collector Output</p>	<p><b>PCR43302R</b> 2-Channel Receiver with Relay Outputs</p>	<p><b>PCR43302RE</b> 2-Channel Receiver with Relay Outputs. Enclosed in a case</p>
			
<p><b>PCR43301240R</b> 1-Channel Receiver with 240VAC mains supply</p>	<p><b>PCR43301240RE</b> 1-Channel Receiver enclosed in an IP66 case</p>	<p><b>PCR43302240R</b> 2-Channel Receiver with 240VAC mains supply</p>	<p><b>PCR43302240RE</b> 2-Channel Receiver enclosed in an IP66 case</p>
			
<p><b>PCR43304R</b> 4-Channel Receiver with Relay Outputs</p>	<p><b>PCR43304RE</b> 4-Channel Receiver enclosed in an IP66 case</p>	<p><b>PCR43305R</b> 5-Channel Receiver with Relay Outputs</p>	<p><b>PCR43305RE</b> 5-Channel Receiver enclosed in an IP66 case</p>

**Technical Data**

Supply Voltage	11 to 28 Volts AC or DC	
Standby Current	21mA stand by at 24VDC	
Frequencies	433.100 to 434.700MHz	
Receiver Sensitivity	0.316uV (-117dBm)	
Operating Temperature Range	-5 to 50°C	
Receiver Memory Storage	Unlimited Remotes	
Decoding System	Encrypted 17 billion codes combinations or On board 12-way code switch	
Outputs	Two change over relay outputs, rated at 10 Amps 240VAC.	
Relay Contacts	Common (C), Normally Closed (NC) & Normally Open (NO)	
Connections	Supply & output: 6-way female connector	
Antenna 1	ANT433 series for long range applications. Antenna wire for short range applications	
Antenna 2	Use second antenna for extended range	
Operating Range	Refer to the remote control or transmitter datasheet	
Dimensions	PCR43302R: 87 x 52 x 20mm	PCR43302RE: 115 x 65 x 40mm
Weight	PCR43302R: 40 grams	PCR43302RE: 180grams
Useable Transmitters	FOB433 series and PCK series	

**Block Diagram**

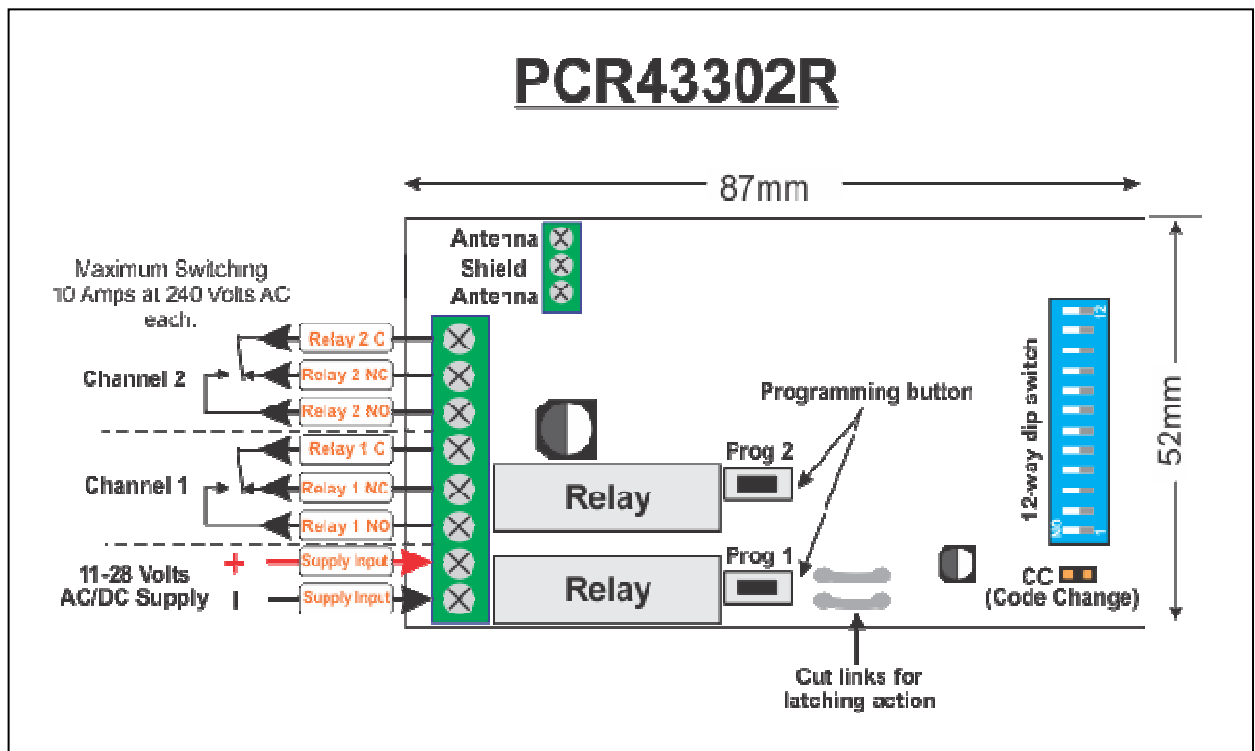

# PentaFOB® Programming Instructions

Coding the PentaFOB® remotes and receivers can be done in 2 different ways.

1. Using the Receiver
2. Using another Remote Control

## Coding using the Receiver

1. Check that all switches are “OFF” on the receivers 12-way dip switch
2. Press and hold the program button on the receiver
3. Press the remote button for 2 seconds, receiver LED will flash and then turn Green
4. Release the button on the receiver and the remote
5. Press remote control button to test the receiver output

## Coding using another Remote Control

1. Open the case of a remote control that is already programmed and press and release the program button on the back of the board
2. Press the new remote control button for 2 seconds
3. Press the new remote control button again to test the receiver output

## Deleting Receivers Memory

Short the Code Reset pins on the receiver for 10 seconds. **This will delete all the remotes from the receiver's memory.**

## PentaFOB® Programmer

This programmer allows you to add and delete certain remotes from the receiver memory. This is used when a remote control is lost or a tenant moves from the premises and the owner wants to prevent un-authorised access.

## PentaFOB® Backup Chips

This chip is used to backup or restore the contents of a receiver. When there are 100's of remotes programmed to a receiver the installer normally backups the receiver memory in case the receiver is damaged.

# PentaCODE Programming Instructions

## 12- Way Dip Switch Coding

1. Set a random code on the receiver dip switch by flicking the dip switches "On" or "Off".  
(DO NOT USE THE DEFAULT FACTORY SETTING FOR THE 12-WAY DIP SWITCH AS THIS IS A COMMON CODE)
2. Open the battery cover in the PentaCODE® remote.
3. Match the 12-way dip switch to the receivers 12-way dip switch.
4. Press button 1 on the remote and the receiver output should activate. This is indicated by the receiver LED.

To program the same PentaCODE® remote buttons 2, 3 or 4 to another receiver change dip switch 11 and 12 in the 2nd, 3rd and 4th receivers. For example:

	Receivers Dip Switch 11	Receiver Dip Switch 12
Receiver 1	Off	Off
Receiver 2	On	Off
Receiver 3	Off	On
Receiver 4	On	On

Dip switches 1 to 10 should all be the same in the remotes and the receivers.

## Encrypted Coding - (All 12-Way Dip Switches must be "Off")

Coding the PentaCODE® remotes and receivers can be done in 3 different ways.

3. Receiver to a Remote
4. Remote to a Receiver
5. Remote to a Remote

### ➤ Receiver to a Remote

1. Press and hold the program button 1 on the receiver.
2. Press the remote button you want to program for 2 seconds, receiver LED will flash Green
3. Release the button on the receiver and the remote.
4. The LED on the PentaCODE® remote will flash to confirm the coding has been successful.

### ➤ Remote to a Receiver / Remote to a Remote

Set one of the remotes or receivers to broadcast its code. The broadcaster's code will be programmed to the other units.

- To broadcast the remotes code make sure all 12 dip switches are "off". Then press and hold button 1 and flick dip switch 12 "on" and then "off". This is confirmed by the LED's being on for 10 seconds. You can release the remotes button 1.

- To broadcast the receivers code make sure all 12 dip switches are "off" and then flick dip switch 12 "on" and then "off". This is confirmed by the green LED being on for 10 seconds.

While broadcasting the code press button 1 on a different remote or receiver for 1 second and then release the button. The LED will flash twice to confirm successful programming.

*Broadcasting will be latched on for 10 seconds or stop if any dipswitch is turned on.*

## Deleting Receivers Memory

Short the CC pin on the receiver for 10 seconds. **This will delete all the remotes from the receivers memory.**